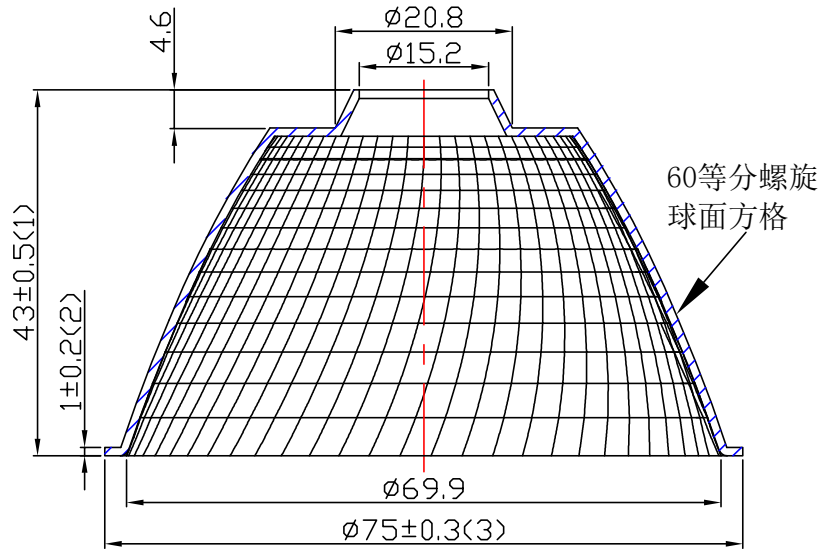
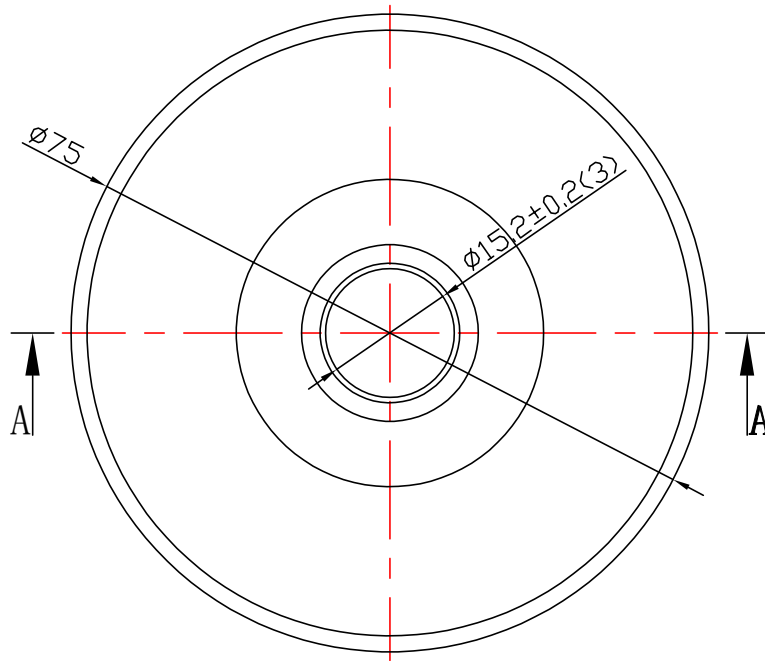

table for unmentioned tolerance in the drawing (unit: mm)			punch angle tolerance in the drawing (unit:degree)		
0-5	5-30	30-120	0-10	10-50	50-120
±0.15	±0.2	±0.5	±1°	±0.5°	±0.3°
120-250	250-400	400-700	120-250	250-360	360 abov
±0.8	±1.5	±2	±0.2°	±0.166°	±0.083°



A — A



Light Source	Luminus CXM-14
PlasticHolder	
Metal Adaptar	
Design Angle	15° ±3°
Measured Angle	
Efficiency	

				Material :1.0 1090AL				Nata[®]				
KO	1							Customer Item				
Mark	Amended Times	Amended Content		Signature	Amended Date			Customer Code		NT		
Controll Version	AO	Design Version	KO	Client Version				Product Number				
Designer	Drawing by		Proporition	1:1				Product Name		2-1102-E		
Technology	Auditor		View	⊕								
Approval	Date		2019. 03. 28	Page	Total_ Page_							